

# 16

High Speed Precision Engine Lathe

**WORLD'S FINEST MACHINE TOOL BUILDER**

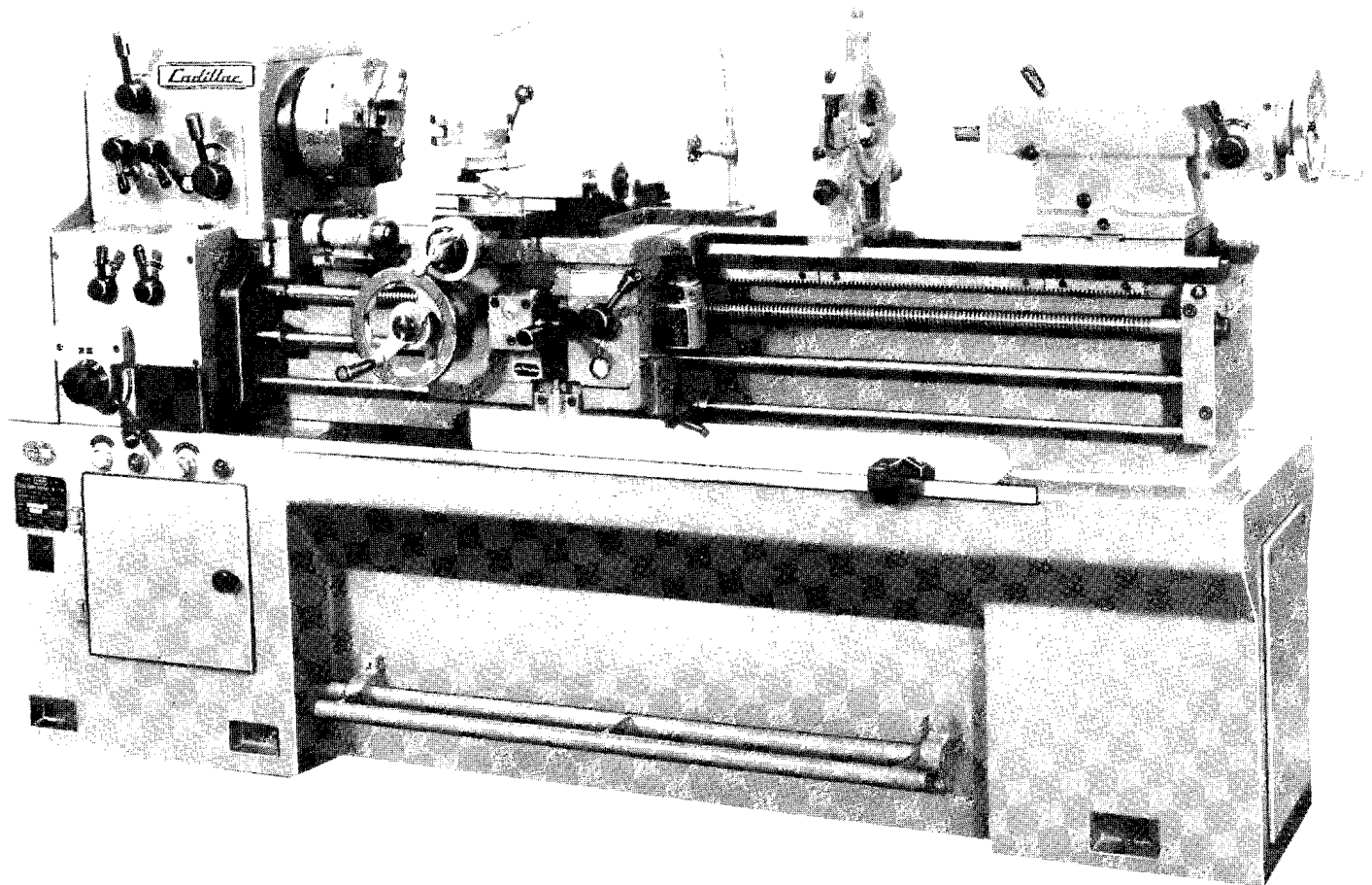

**35 YEARS, SAME FACTORY**

**16"x30"cc GAP 25"**

**16"x40"cc GAP 25"**

**SMOOTH, QUIET, POWERFUL . . . WITH A HOST OF OUTSTANDING FEATURES**

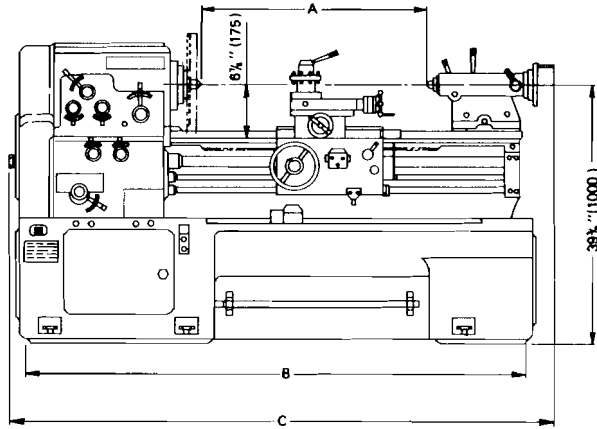
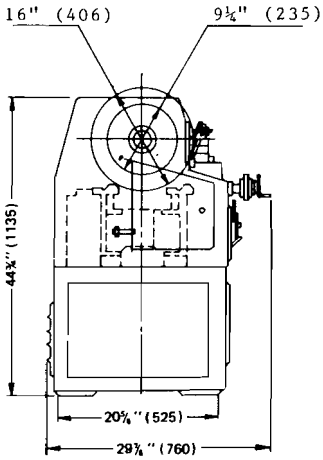

SIZE TYPE	A	B	C
1530	30"	66"	70"
1540	40"	79"	83"

**SPECIFICATIONS**

CAPACITIES	Swing over bed	16"		
	Swing over cross slide	9 1/2"		
	Distance Between Centers	30"	40"	
HEADSTOCK	Number of speeds	6/12		
	Range of speeds 1SP-2SP	67, 125, 210, 420, 800, 1350/102,180, 320, 650, 1200, 2000		
	Spindle nose	JIS A1-5 or D1-5		
	Taper in spindle nose bushing	M.T. NO. 6		
	Spindle center	M.T. NO. 3		
	Hole thru spindle	1-49/64"		
CARRIAGE	Number of feeds	32		
	Longitudinal feeds	0.001-0.020		
	Cross feeds	0.04 — 0.52		
	Cross slide travel	8 1/2"		
	Compound rest travel	4"		
THREADS	Range of Whitworth threads	4 1/2, 5, 5 1/2, 6, 6 1/2, 7, 8, 9, 10, 11, 12, 13, 14, 16, 18, 19, 20, 24, 26, 28, 32, 36, 40, 44, 48, 56		
	Range of Metric threads	7, 6, 5, 4.8, 4.5, 4, 6.4, 5.6, 3.5, 3, 2.5, 2.4, 2, 3.2, 2.8, 1.75, 1.5, 1.25, 1.2, 1, 1.6, 1.4, 0.75, 0.6, 0.5, 0.8, 0.7, 0.9, 1.8		
	Lead screw, dia.	1"		
TAILSTOCK	Center	M.T. NO. 4		
	Spindle travel	4 1/4"		
BED	Length	60"	71"	
	Width	10 3/4"		
	Depth	10 1/4"		
MOTOR	Main Motor	5HP		
FLOOR SPACE	Length	71"	83"	
	Width	30"		
	Height	45"		
Net Weight		3316	3480	

**STANDARD EQUIPMENT**

- 8" dia. driving plate . . . . . 1 pc.
- Centers; M.T. No. #3, #4 . . . . . 2 pcs.
- Sleeve; M.T. No. #5 . . . . . 1 pc.
- Tool kit . . . . . 1 set
- Foundation pads . . . . . 1 set
- Coolant pump . . . . . 1 set
- Steady rest . . . . . 1 set
- Face plate 11" . . . . . 1 set
- 2 speed tailstock . . . . . 1 pc.
- Change gears 35T, 48T, 54T . . . . . 3 pcs.
- Comb. inch/metric dials . . . . . 1 set
- Follow Rest . . . . . 1 set

**EXCLUSIVE IMPORTER**

**DISTRIBUTOR**

